

4. PRECISION LIFTING SOLUTIONS



Designed to lift or lower objects in a controlled manner, the VLW range will give a safe, smooth, secure hold when lifting or lowering heavy equipment.

Using the Equalizer™ interlocking first-step technology, this tool will lift an object in a stable movement from an access gap of only 9.5mm (0.37”).



VLW18TE
Actuated by an external hydraulic hand-pump



VLW18TI
Actuated by an integral hydraulic hand-pump, so no hoses or external pumps are required

SPECIAL FEATURES

- smooth, straight, vertical lift
- operates with an access gap of only 9.5mm (0.37”)
- each step offers 19.0mm (0.75”) of vertical lift
- maximum lift using stepped block 67.5mm (2.66”)
- single acting ram
- lifting force of 180kN (18T)
- automatic manual retraction
- interlocking first step



VLW18TI
STANDARD KIT

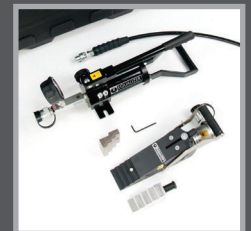

VLW18TE
STANDARD KIT



"innovation in its most functional form"

PRODUCT DATA SHEET

VLW18TE

HYDRAULIC VERTICAL
LIFTING WEDGE

MAXI-KIT

Product Code: VLW18TEMAXSPB

LIFTING FORCE:
10,000psi (700Bar)
18T (180kN)

TOOL WEIGHT:
8.5kg (18.8lb)

KIT COMPONENTS

- 2 x VLW18TE Wedgeheads
- 2 x 10,000psi (700bar) Hydraulic Hoses, 2m (78.75")
- 2 x 10,000psi (700bar) Hydraulic Cylinders
- 1 x 10,000psi (700bar) HP350D Sealed Hand Pump with Gauges
- 2 x Safety Blocks
- 2 x Stepped Blocks
- 2 x Hex Keys
- 2 x Countersunk Screw
- 1 x Instruction Manual
- 1 x Carry-Case

WEIGHTS & DIMENSIONS

Wedge (with Hydraulic Cylinder):	8.5kg	(18.7lb)
Carry-Case	6.0kg	(13.2lb)
Gross Weight	33.0kg	(72.8lb)



Carry-Case Dimensions:
920 x 520 x 210mm (36.22" x 20.47" x 8.26")

TOOL DIMENSIONS - CLOSED

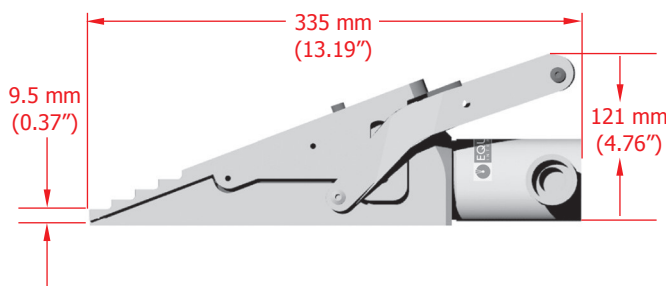

TOOL DIMENSIONS - OPEN

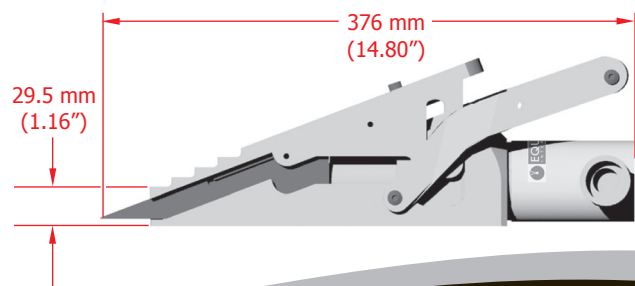

VLW18TE

HYDRAULIC VERTICAL LIFTING WEDGE



"innovation in its most functional form"

TOOL DIMENSIONS - CLOSED

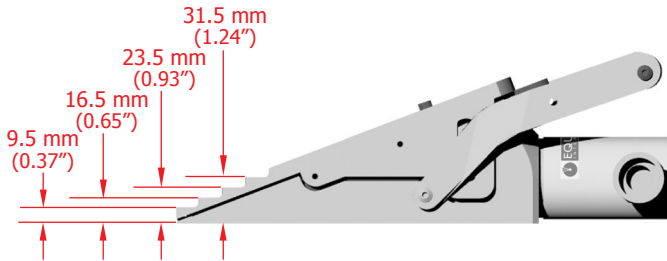

TOOL DIMENSIONS - OPEN

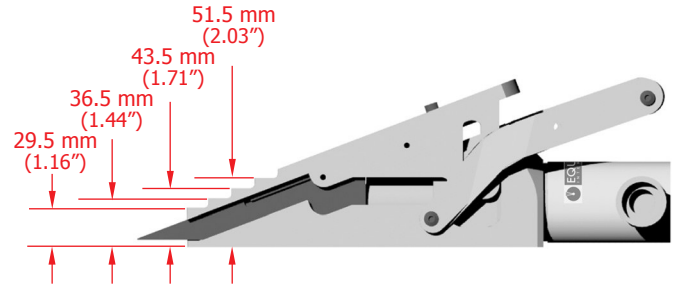

SAFETY BLOCK DIMENSIONS

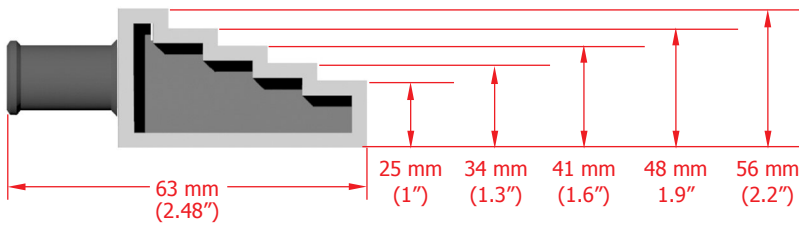

STEPPED BLOCK DIMENSIONS

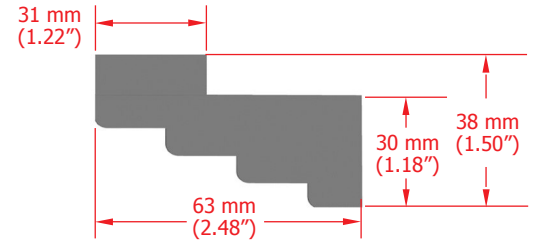

ITEM	PART No.	DESCRIPTION	QUANTITY
01	501301-01	HANDLE BAR	01 each
02	402902-04	SCREW FOR HANDLE	01 set of 4
03	501001-02	SIDE PLATES FOR HANDLE	01 set of 2
04	402701-01	SCREW FOR TAIL	01 each
05	501601-01	WASHER FOR TAIL	01 each
06	500201-01	TOP PLATE	01 each
07	501901-01	STEPPED BLOCK (KIT)	01 kit
08	301201-04	ROLL PINS	01 set of 4
09	502001-01	TAIL	01 each
10	501501-02	SCREWS FOR TAIL	01 set of 2
11	501401-01	SAFETY BLOCK	01 each
12	500302-01	WEDGE	01 each
13	301301-01	GRUB SCREW	01 each
14	503201-01	SLOT PLUG	01 each
15	500102.01	MAIN BODY	01 each
16	503501-02	SPACER	01 set of 2
17	503301-02	WASHER 10 mm ID	01 set of 2
18	503401-02	WASHER 6 mm ID	01 set of 2
19	500401-02	SLIDE PINS	01 set of 2

ITEM	PART No.	DESCRIPTION	QUANTITY
20	502301-01	M6 x 35mm GRUB SCREW	01 each
21	500503-01	PUSH PIN MK III	01 each
22	301002-01	HYDRAULIC CYLINDER	01 each
23	300401-02	GRUB SCREW FOR SLIDE PINS	01 set of 2
24	310601-01	GREASE NIPPLE	01 each
25	201201-01	RUBBER SLEEVE	01 each
26	301403-01	CYLINDER REPAIR KIT (Not Illustrated)	01 kit

PARTS LIST & EXPLODED DRAWING

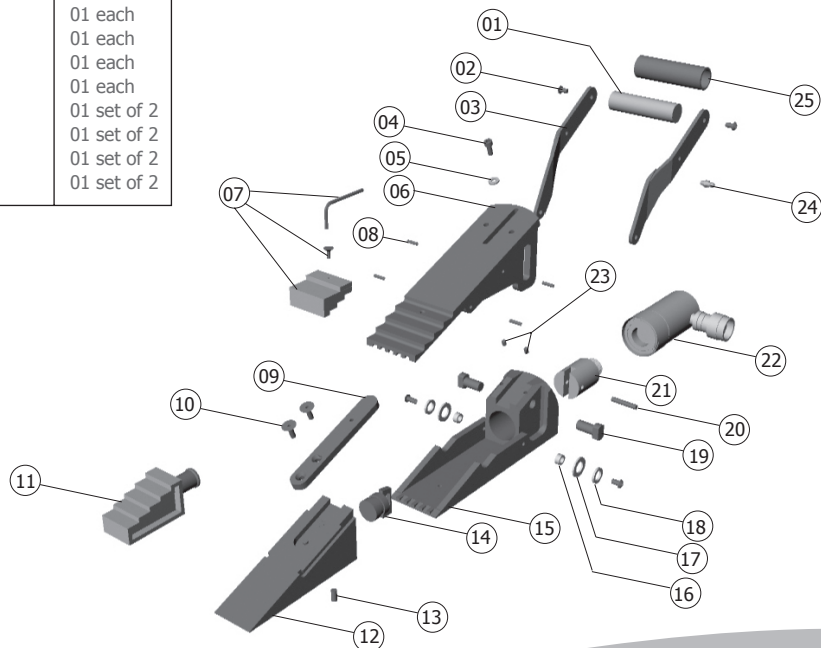



"innovation in its most functional form"

PRODUCT DATA SHEET

VLW18TI

INTEGRAL HYDRAULIC VERTICAL LIFTING WEDGE

LIFTING FORCE:
10,000 psi (700 bar) = 18 T (180 kN)

TOOL WEIGHT = 12 kg (26.5 lbs)

KIT COMPONENTS

- 1 x VLW18TI Wedgehead
 - 1 x 10,000 psi (700 bar) Integral Hydraulic Pump/Cylinder
 - 1 x Safety Block
 - 1 x Stepped Block
 - 1 x Hex Key
 - 1 x Countersunk Screw
 - 1 x Instruction Manual
 - 1 x Carry Case
- Product Code: VLW18TISPB



WEIGHTS AND DIMENSIONS

Tool Weight = 12 kg (26.5 lbs)
Case Weight = 2.5 kg (5.5 lbs)
Gross Weight = 14.5 kg (31.9 lbs)

Carry Case Dimensions:
580 x 340 x 180mm (22.8" x 13.4" x 7.1")

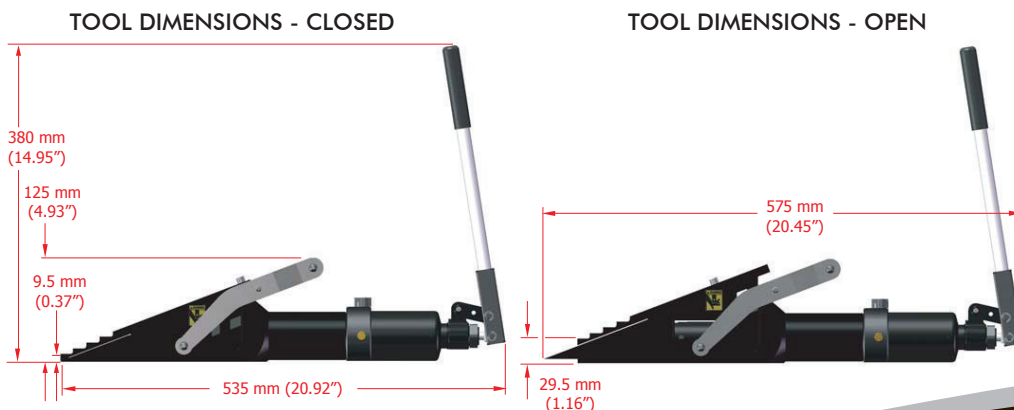

info@equalizerinternational.com
www.equalizerinternational.com

VLW18TI

INTEGRAL HYDRAULIC VERTICAL LIFTING WEDGE



"innovation in its most functional form"

TOOL DIMENSIONS - CLOSED

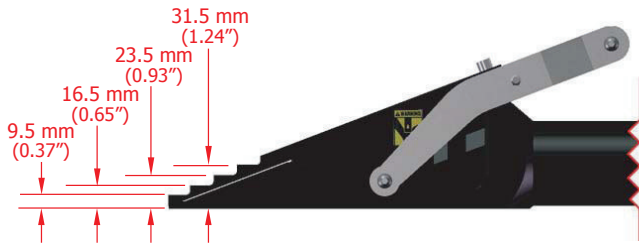

TOOL DIMENSIONS - OPEN

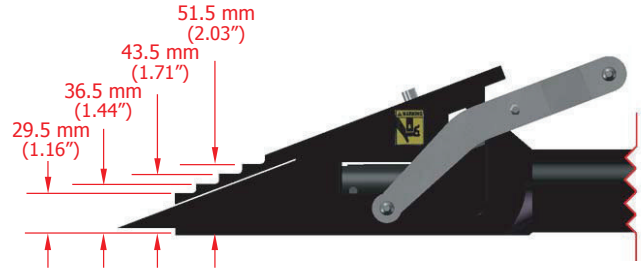

SAFETY BLOCK DIMENSIONS

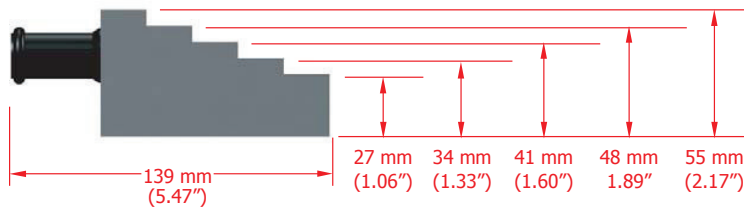

STEPPED BLOCK DIMENSIONS

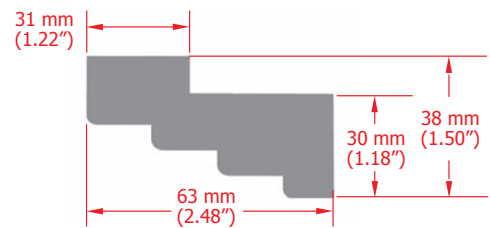

PARTS LIST AND EXPLODED DRAWING

ITEM	PART No.	DESCRIPTION	QUANTITY
01	060701-01	ALLEN KEY	01 each
02	070012-01	SERIAL NO STICKER	01 each
03	070014-01	PINCH POINT STICKER	02 each
04	070054-01	QC SEALED STICKER	02 each
05	070098-01	EQUALIZER LOGO	01 each
06	070249-01	READ INSTRUCTION STICKER	01 each
07	201203-01	HANDLE SLEEVE	01 each
08	300401-01	SCKT SET SCREW	02 each
09	301201-01	SPIROL PIN	04 each
10	301301-01	GRUB SCREW	01 each
11	310601-01	GREASE NIPPLE	01 each
12	402701-01	SCKT HEAD CAP SCREW	01 each
13	402902-01	SCREW FOR HANDLE	05 each
14	500101-01	MAIN BODY	01 each
15	500201-01	TOP PLATE	01 each
16	500302-01	WEDGE TAIL	01 each
17	500401-01	GUIDE PIN	02 each
18	500503-01	PUSH PIN MK III	01 each
19	501101-01	HANDLE LEFT	01 each
20	501201-01	HANDLE RIGHT	01 each
21	501301-01	HANDLE BAR	01 each
22	501401-01	SAFETY BLOCK	01 kit
23	501601-01	WASHER FOR TAIL	01 each
24	501901-01	STEP BLOCK	01 each
25	502301-01	GRUB SCREW	01 each
26	503201-01	SLOT PLUG	01 each
27	503301-01	WASHER	02 each
28	503401-01	WASHER	02 each
29	503501-01	SPACER	02 each
30	510701-01	PUMP MODEL PM1004UK	01 each
31	375010-01	SERVICE KIT A (not illustrated)	01 each
32	375020-01	SERVICE KIT C (not illustrated)	01 each
33	510700-01	SERVICE KIT D (not illustrated)	01 each

